

Engineering sample data
MODULE ASSEMBLY
2003 Nov 26

HM199

Refrigeration control with audible condensor alarm and lockout

INTEGRATED ELECTRONIC SOLUTIONS
1 BUTLER DRIVE
HENDON SA 5014
AUSTRALIA



Refrigeration control with audible condensor alarm and lockout

HM199**CONTENTS**

1	FEATURES
2	GENERAL DESCRIPTION
3	QUICK REFERENCE DATA
4	ORDERING INFORMATION
5	CONNECTION DRAWING
6	DIMENSIONS
7	ASSEMBLY DRAWINGS
8	FUNCTIONAL DESCRIPTION
8.1	OM1894 Technical background
9	IMPORTANT: ELECTRICAL SAFETY WARNING
10	RATINGS
11	CHARACTERISTICS
12	CIRCUIT FUNCTION
12.1	The refrigerator cabinet control circuit
12.2	The evaporator control circuit
12.3	The condenser alarm circuit
12.4	Accuracy
12.5	Failure table
13	APPLICATION INFORMATION
13.1	Application Check List
13.2	Thermistor mounting considerations
13.3	Heatsink and triac temperature and load considerations
13.3.1	Thermal considerations
13.3.2	Triac specifications
13.3.3	Heatsink temperature rise
13.3.4	Current rating
13.4	Radio Frequency Interference
14	DEFINITIONS3
15	IES INFORMATION
16	DISCLAIMER

Refrigeration control with audible condenser alarm and lockout

HM199

1 FEATURES

- Precise temperature control
- Designed to drive inductive loads (compressor motors).
- True load current Zero-crossing switching (minimises EMI).
- Refrigerator cabinet and evaporator sensing and control
- Audible over-temperature alarm for the refrigerant condenser temperature
- Automatic compressor shut-down on condenser "overtemperature" to avoid compressor failure.
- Optional 5 minute compressor lock-out timer, to prevent start of compressor cycle while system is pressurised.
- User adjustable refrigerator cabinet temperature
- Used with NTC Thermistor temperature sensors

2 GENERAL DESCRIPTION

The HM199 is an electronic refrigeration thermostat control module which uses three temperature sensors. The compressor is controlled by the cabinet temperature when the food cabinet sensor calls for cooling, depending on its set temperature. However it is prevented from starting a cooling cycle by a sensor mounted on the

evaporator which will not allow cooling to begin until the evaporator has reached a preset temperature above zero degrees, and all ice on the evaporator has melted. Also if the evaporator falls below -10°C the compression cycle is concluded, to enforce defrosting of the evaporator.

An audible alarm is controlled by a third thermistor mounted on the refrigerant condenser. If the accumulation of dust and fluff so insulates the condenser that it runs warmer than usual, at a preset temperature the alarm begins to sound and latches on; and at a slightly higher condenser temperature cancels the compressor run cycle latching the compressor off.

An optional 5 minute lock-out timer will prevent the start of a compressor run cycle within 5 minutes of the end of the previous run cycle. This prevents the compressor trying to start when the refrigerant is still pressurised. It also allows for the use of low-start-torque compressors, which do not need to start against refrigerant back-pressure.

Using an OM1894 Dual Sensing Triac Control Thermostat IC, the HM199 will provide improved performance.

The temperature control range of the HM199 thermostat is set during manufacture, however other temperature values can be provided on request.

3 QUICK REFERENCE DATA

SYMBOL	PARAMETER	CONDITIONS	MIN.	TYP	MAX.	UNIT
V_{SUP}	AC supply voltage		216	230	253	V
I_{SUP}	control supply current	controller only	–	7	–	mA
I_{LOAD}	load current	triac mounted on HM199	–	–	6	A
T_{cab}	cabinet temperature	adjustment range	2	set	20	$^{\circ}\text{C}$
T_{evap}	cabinet cooling may not begin until the evaporator temperature is above T_{evap}		–	3.5	–	$^{\circ}\text{C}$
$T_{\text{evap-defrost}}$	evaporator forced defrost temperature		–	-10	–	$^{\circ}\text{C}$
T_{alarm}	condenser audible alarm temperature		–	60	–	$^{\circ}\text{C}$
T_{lockout}	condenser lockout temperature		–	65	–	$^{\circ}\text{C}$
t_{lockout}	compressor lockout time	(when fitted)	4.5	5.0	5.5	mins
T_{stg}	storage temperature		-25	–	$+85$	$^{\circ}\text{C}$
T_{amb}	operating ambient temperature	in free air	0	–	$+60$	$^{\circ}\text{C}$

Refrigeration control with audible condenser alarm and lockout

HM199

4 ORDERING INFORMATION

TYPE NUMBER	DESCRIPTION	
	SUFFIX	DESCRIPTION
HM199	L P	Lock-out timer option On-board potentiometer option
Examples:		
HM199	-LP	refrigerator control module, with lock-out timer, on-board potentiometer
HM199	-L	refrigerator control module, with lock-out timer, remote potentiometer

5 CONNECTION DRAWING

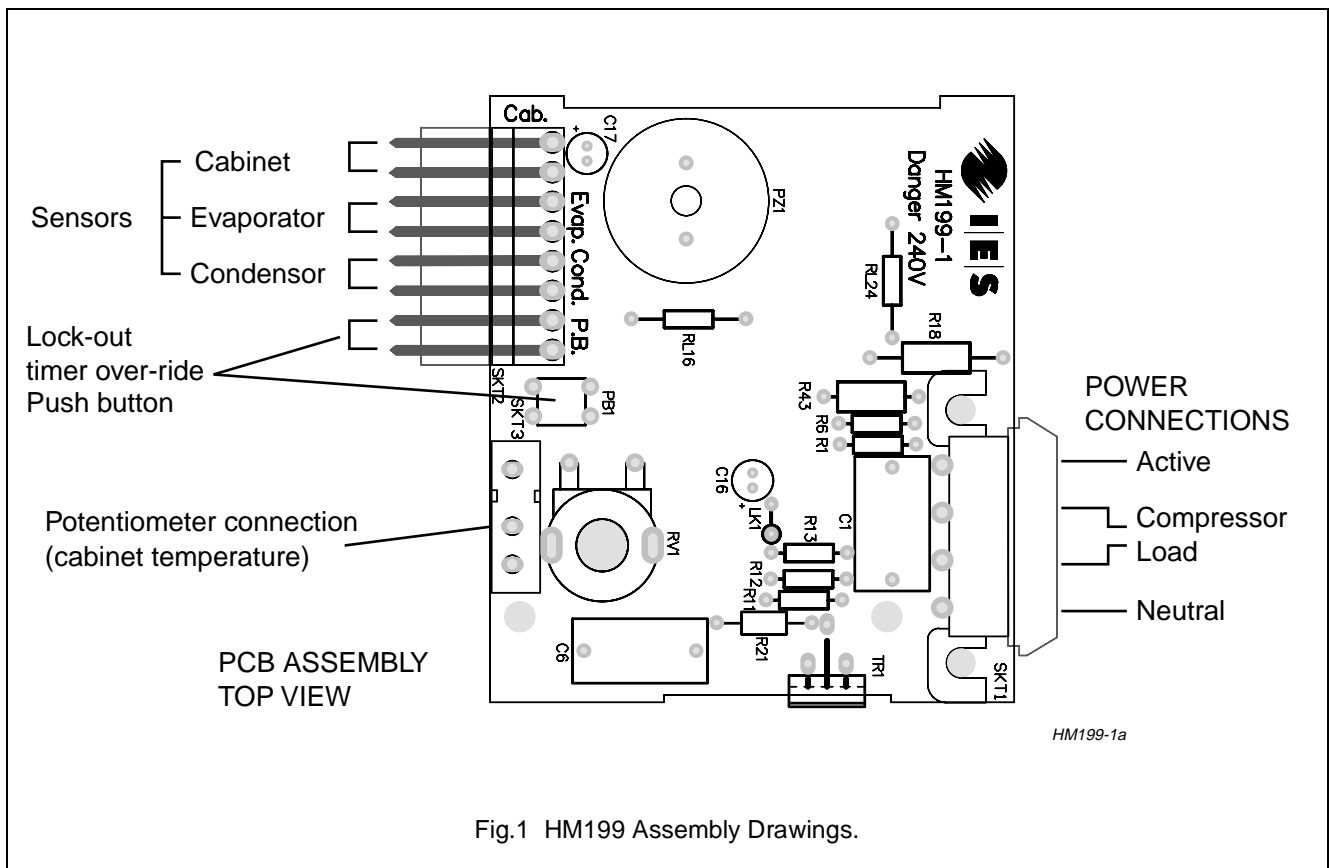

Fig.1 HM199 Assembly Drawings.

Refrigeration control with audible
condensor alarm and lockout

HM199

6 DIMENSIONS

Power Connector: AMP Plug 0-0350779-1 (4p UMNL PLUG HSG RD) with Pin 0-0350547-1 (Contact pin UMNL)
 Potentiometer assembly: 500 mm overall length. Connector Stelvio BS95/3 with CT84 contacts.
 Insulated NTC Thermistor probes 2k2 and 47k, length 1200 mm, Plug Molex 09-91-0200 with pin 08-50-0106.

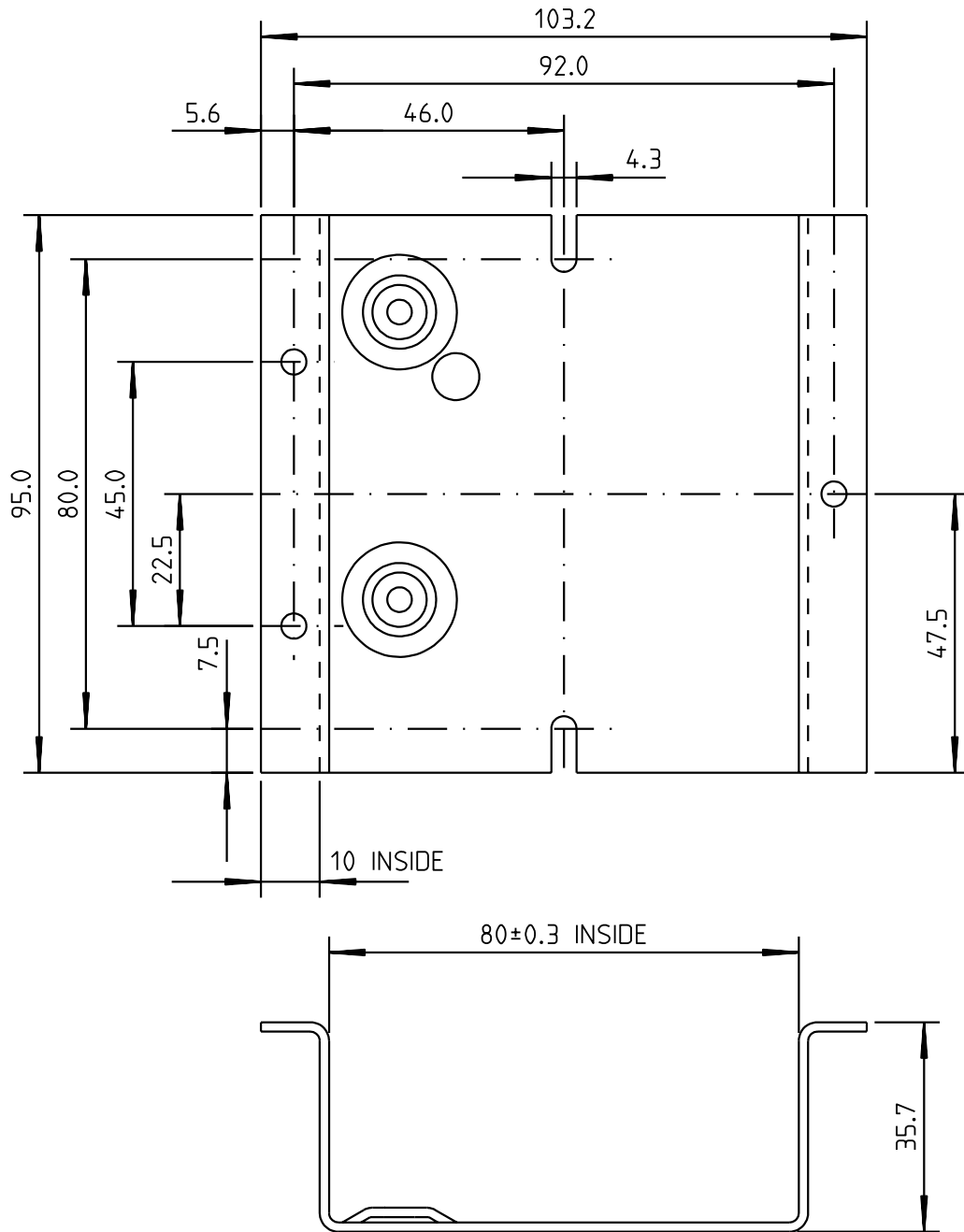

Fig.2 HM199 Dimensions.

Refrigeration control with audible
condensor alarm and lockout

HM199

7 ASSEMBLY DRAWINGS

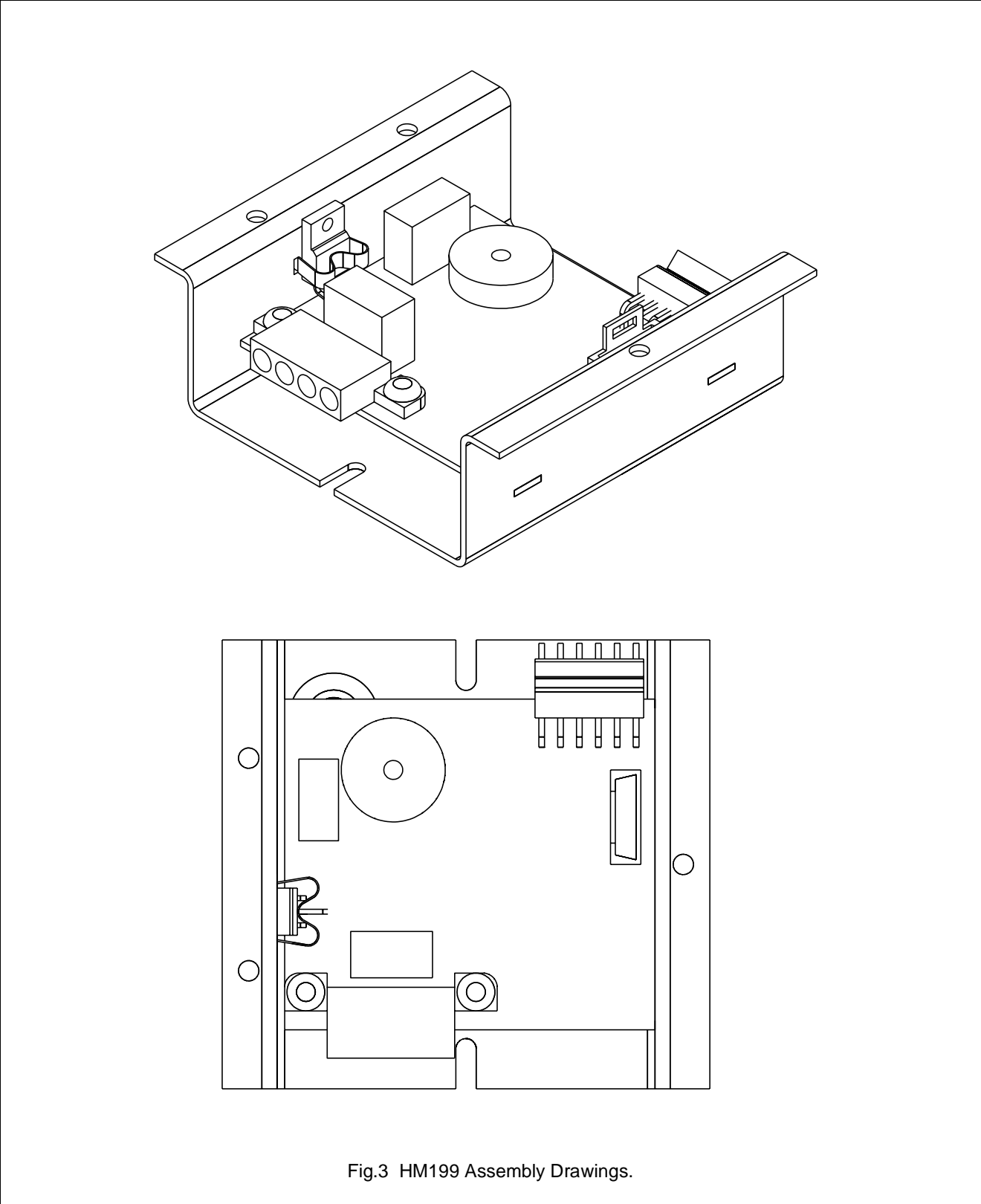

Fig.3 HM199 Assembly Drawings.

Refrigeration control with audible condensor alarm and lockout

HM199

8 FUNCTIONAL DESCRIPTION

The HM199 refrigerating electronic control module offers an accurate general purpose control module for triac control of a refrigerator.

The NTC thermistor mounted in the refrigerator cabinet provides the control function for the compressor using an OM1894 Dual Sensing Triac Control Thermostat IC, regulating the food or drink compartment to the set temperature. This function is modified by another NTC thermistor which is mounted on the evaporator panel, and over-rides the control signal to ensure that a cooling cycle is only permitted to begin if the evaporator temperature has risen to a temperature sufficiently above freezing to ensure all ice has melted. In addition, if the evaporator ices up during a compression cycle to the extent that its efficiency is reduced for its temperature to fall below a set temperature well below freezing, then

it will stop the compression cycle, to allow the ice to melt before another compressor cycle is permitted to begin.

A third NTC thermistor measures the temperature of the condenser to ensure that it does not run too hot when the accumulation of dust etc. reduces its thermal efficiency in condensing the refrigerant. When it reaches the set alarm temperature an audible alarm starts, and is latched ON, continuing to sound the alarm until it is reset by switching off the mains supply. At a slightly higher temperature than the set alarm temperature, the alarm circuit also sets another latch to hold the compressor OFF until after a service call. These latched alarm and lockout conditions can be reset by switching the mains power off for more than 30 seconds.

8.1 OM1894 Technical background

The HM199 circuit is based on the Dual Sensing Triac Control Thermostat zero-crossing triac driver OM1894 in a circuit which thermostatically controls a load using three external NTC (Negative Temperature Coefficient) thermistors as the temperature sensors. The OM1894 has been designed to handle inductive loads such as compressor motors.

For a detailed description of the functioning of the OM1894 integrated circuit refer to the Data Sheet "OM1894 Dual Sensing Triac Control Thermostat". There are also application notes available which describe the design of power supply and circuits for the OM1894.

9 IMPORTANT: ELECTRICAL SAFETY WARNING

The HM199 circuit is connected to the mains electrical supply and operates at voltages which need to be protected by proper enclosure and protective covering. While it has been designed to conform to relevant standards (such as IEC 65, or Australian Standards AS3100, AS3250 and AS3300), it should only be used in a manner that ensures the appliance in which they are used complies with all relevant national safety and other Standards.

The board must be mounted with non-conductive clips, and positioned such that the minimum creepage distance from the assembly to earth paths, and between high voltage points is not transgressed.

The NTCs and the triac are electrically live and connected to the mains, and must therefore be adequately electrically insulated. Also, creepage distances must be maintained for live parts of the NTC and triac.

It should be noted that there are Mains Voltages on the circuit board. Adequate labelling should be attached to warn service personnel, and others, that this danger exists.

The control board assembly must be mounted, preferably vertically, with sufficient free air flow across its surface to prevent heat, dissipated in a number of critical components, and particularly the heatsink to which the triac is mounted, from causing an unacceptable rise in the ambient temperature.

The board should be mounted in a place that is clean and dry at all times, not subject to condensation or the accumulation of dust and other contaminants.

Refrigeration control with audible condensor alarm and lockout

HM199

10 RATINGS

In accordance with the Absolute Maximum Rating System (IE C134)

SYMBOL	PARAMETER	LIMITS		UNIT
		MIN.	MAX.	
V _{SUP}	AC supply voltage	216	253	V
I _{LOAD}	Load current (triac on HM199 board and heatsink) (see notes)	–	6	A
I _{STARTUP}	Start up surge current (1 sec max)	–	35	A
T _{stg}	storage temperature range	–25	+85	°C
T _{amb}	operating ambient temperature range (see notes)	0	+60	°C

Notes

1. See the discussion of the HM199 heatsink capability in section 13.3. The triac junction temperature should remain below 125 °C at full load, and maximum ambient: to be verified by measurement in situ.
2. The current rating and maximum operating ambient temperature is for the heatsink mounted vertically in free air.

11 CHARACTERISTICS

SYMBOL	PARAMETER	CONDITIONS	MIN	TYP	MAX	UNIT
I _{SUP}	controller current (AC))		–	7	–	mA _{rms}
T _{cabinet(start, pot max, cold)}	cabinet temperature (compressor start)	temp. set pot on coldest setting (maximum resistance)	2	3	4	°C
T _{cabinet(stop, pot max, cold)}	cabinet temperature (compressor stop)	temp. set pot on coldest setting (maximum resistance)	0	1	2	°C
T _{cabinet(start, pot min, warm)}	cabinet temperature (compressor start)	temp. set pot on warmest setting (minimum resistance)	19	20	21	°C
T _{cabinet(stop, pot min, warm)}	cabinet temperature (compressor stop)	temp. set pot on warmest setting (minimum resistance)	17	18	19	°C
T _{evaporator (start)}	evaporator temperature (compressor permitted to start)	evaporator warmer than this temperature	2	3.5	4.5	°C
T _{evaporator (stop)}	evaporator temperature (compressor forced to stop)	evaporator colder than this temperature	–8	–10	–12	°C
T _{condensor alarm}	alarm temperature (audible alarm starts and latches ON)		58	60	62	°C
T _{condensor lockout/stop}	condenser temperature at which compressor is stopped	latch–OFF trip temperature	63	65	67	°C

Notes

1. The Compressor may only start IF (1) the cabinet temperature is above the set temperature, AND (2) the evaporator has reached the evaporator start temperature, AND (3) the condenser has not exceeded the condenser stop temperature. All three conditions must be satisfied.
2. The compression cycle will end IF (1) the cabinet temperature has fallen below its set stop temperature, OR (2) the evaporator temperature has fallen below the evaporator stop temperature, OR (3) the condenser has exceeded its lockout temperature.

Refrigeration control with audible condensor alarm and lockout

HM199

12 CIRCUIT FUNCTION

The characteristics are given for the proposed circuit configuration and component values for the HM199. These can easily be re-calculated to operate at other temperatures depending on the specific needs of a particular application.

The HM199 uses very small currents, and has a total power dissipation of less than 1.5 watts. However the heat dissipated in the triac is significant, and its heatsink temperature, and how effectively it is cooling the triac needs to be checked.

The circuit of the HM199 is best considered as consisting of three circuit modules and their functions. These are the refrigerator thermostat, the evaporator control functions, and the alarm circuit.

12.1 The refrigerator cabinet control circuit

The OM1894 driving the compressor is controlled by a thermistor monitoring the temperature of the cabinet and its contents. This is configured as a normal OM1894 refrigerator thermostat.

In addition an open collector transistor pull-down is provided to the CAP pin as an output from the evaporator control circuit and the alarm to force or hold the compressor drive in the off condition.

12.2 The evaporator control circuit

The evaporator thermistor is connected in an ac bridge circuit driving a long-tailed pair differential amplifier using two transistors. This circuit is inactive during the negative half cycles, and only provides an output if the signal across the evaporator thermistor is greater than the trip level at that time. There is a large hysteresis feedback signal taken from across the control triac to

the thermistor to provide two trip points depending on whether the compressor is running or not.

Thus, when the compressor is not running, additional voltage is applied to the evaporator thermistor side of the bridge to only allow the next compressor run cycle to begin after the evaporator has warmed enough to melt all of the ice. When the evaporator is warm enough the collector signal from T3 ceases to continually reset the signal on the OM1894 pin CAP to a compressor OFF state.

When the triac is ON, there is no longer a large ac voltage across the triac being applied to the thermistor arm of the bridge. This moves the trip point to a temperature about 10 degrees colder. Until the evaporator falls to a temperature of less than this new trip point, the transistor T3 is off all of the time, and the compressor is allowed to run.

12.3 The condenser alarm circuit

A third bridge circuit sets an alarm temperature from the thermistor mounted on the condenser. This is outside the refrigerator cabinet, and for efficiency should be in circulating air, cooled to the outside ambient. However if fluff and dust accumulates its ability to lose heat and operate efficiently is curtailed, and it runs at a higher temperature with a significant loss in efficiency.

This bridge circuit operates with a double long tailed pair of balanced transistor amplifiers, with as small threshold difference between them. The first threshold starts the alarm, latching the alarm generator on. When the condenser reaches a temperature of 4 degrees warmer, the second balanced amplifier reaches its threshold, and also latches, acting to stop the compressor running via the transistor which holds the voltage on the OM1894 CAP pin low.

The alarm sound is generated by a piezo sounding element driven in a bridged output configuration by a dual latching oscillator made up from an HEF40106 hex schmitt inverter integrated circuit. The audible alarm circuit has its own negative power supply, and therefore can be varied in sound level and tone by changing component values without affecting the performance of the rest of the circuit

Once the audible alarm oscillator has started sounding, and the OFF latch has been set, the only way to release their latch on situation is to remove the mains supply for sufficient time (about 30 seconds) for the power supplies to fully discharge and reset the latches.

12.4 Accuracy

Using the HM199 will improve overall accuracy typically to better than ± 1 °C.

When a potentiometer is used it obviously becomes possible to set the temperature to any desired point within its range. The input measuring circuit is a balanced bridge, and therefore any variation in mains voltage is cancelled, and has no effect on the set temperature. Likewise the input measuring circuit of the OM1894 is also balanced. However repeatable positional settings from appliance to appliance will be subject to the potentiometer tolerance, usually 10 to 20%, which will affect the minimum set temperature end of the potentiometer range only (at the maximum set temperature, the potentiometer is short circuit). The designer can allow for such component tolerances by making the adjustment range wider than that specified at the colder end of the temperature adjustment range.

Refrigeration control with audible condenser alarm and lockout

HM199

12.5 Failure table

As the thermistors are remote from the HM199, there is a possibility that these wires may either be short circuited, or may become open circuit. The table below shows the results of such a failure. It also shows what

occurs if the wiper on the potentiometer becomes open/short circuit through contamination from dust etc., or if remote leads are fitted to a panel mounted potentiometer.

Sensor/potentiometer failure table

FAILURE MODE	RESULTING FUNCTION
NTC1 (cabinet) open circuit	No cooling
NTC1 (cabinet) short circuit	Continuous cooling unless over-ridden by the evaporator or alarm condition
Set temperature potentiometer wiper arm open circuit	Run at coldest set point
Potentiometer wiper arm shorted to Common	Run at warmest set point
NTC2 (evaporator) open circuit	No cooling
NTC2 (evaporator) short circuit	No defrost function, refrigerator cooling to set cabinet temperature without defrost feature
NTC3 (condenser) open circuit	No alarm functions
NTC3 (condenser) short circuit	Continuous alarm, compressor locked out and cannot start.

13 APPLICATION INFORMATION

In this section a number of important issues are addressed. These points must be considered before a final HM199 design is acceptable for performance and reliability in a given required function.

13.1 Application Check List

1. Application: The refrigeration function using thermistors, one mounted in the cabinet, and others monitoring the evaporator and condenser temperatures. An evaporator mounted thermistor modifies the cooling behaviour of the refrigerator to ensure defrost every cooling cycle. An audible alarm function is controlled by the condenser temperature.
2. What will be the current load under normal conditions? The load current must be capable of being controlled by the triac. This must be considered both for

normal operation as well as for possible abnormal conditions. For example, the refrigerator compressor motor presents an increased current load under stall and starting conditions.

3. The triac has been mounted on a heatsink which is part of the HM199 module. For average loads of less than a steady 6 amps the copper tracks on the HM199 printed circuit board are adequate to carry this current. For a larger compressor run currents much exceeding 6 amps testing will need to be carried out to confirm current capability of the PCB layout, as well as for the ability of the heatsink to adequately cool the triac.
4. What power will be dissipated in the triac? The triac has a rated maximum operating junction temperature, and if this temperature is exceeded it is possible that the triac will switch

ON (or stay ON) even without a gate signal. It is therefore necessary to ensure that under all operating conditions, including possible abnormal conditions, the junction will not exceed this maximum temperature. This is done by using a heatsink to conduct the heat away from the triac, and to dissipate this heat via the free flow of air across a sufficiently large surface area.

13.2 Thermistor mounting considerations

As the thermistors are electrically live to mains voltages they must be adequately insulated for use in each application. A range of insulated thermistors are available, and there are a number of important issues which must be considered in mounting them.

The best way in which to mount the thermistor is to clamp along the length

Refrigeration control with audible condensor alarm and lockout

HM199

of the lead for about 50 mm starting just clear of the sensing "head" of the lead. Ideally the black plastic head of the leaded thermistor should all be clear of the mounting clamp by a distance of at least 1 to 5 mm.

The sensing head of an insulated leaded thermistor should never be clamped in a manner which puts it under physical pressure. If it is clamped too tightly, the ceramic thermal sensing element may be cracked and damaged.

The plastic covered thermistor does not have a large thermal mass, and especially in moving air, will arrive quite quickly at a temperature very close to that of the ambient air. The clamping means can also allow heat to flow to/from the copper wires leading to the thermistor, and can provide a significant modification to the temperature seen by the thermistor. If the sensing point is also associated with a significant thermal mass such as a shelf or a panel, averaging, and a thermal delay to sense ambient changes can result, possibly providing much more desirable response characteristics. However, when mounted in an active air stream, without thermally conductive paths to surrounding objects, it can give sensing which is very sensitive to even small variations in air temperature.

13.3 Heatsink and triac temperature and load considerations

As the triac junction temperature must always remain below its rated maximum temperature, and the current carrying capability of the wiring must also be such as to maintain safe and reliable operation during life, there are a number of considerations which must be examined before a new application is released to production.

The voltage drop across the triac is typically 1.5 volts giving a significant power dissipation at full run current. In addition the resistance of the wiring and the printed circuit board tracks have heat losses. This heat loss raises the temperature of the triac junction, and also of the wiring above the ambient temperature. It is necessary to ensure that at no time are rated temperatures exceeded, and that this heat can be safely dissipated and carried away.

If the HM199 controller is run in a warmer ambient environment it must be checked to ensure that the temperature rise above ambient remains within safe limits. If the temperature rise is found to be excessive then there a number of steps that can be taken to ensure safe operation.

This is discussed in more detail in the following sections below.

13.3.1 THERMAL CONSIDERATIONS

To prevent overheating there are three ways in which the heat generated by the triac and in the wiring can be dissipated. First the heat is carried by conduction to a dissipating surface with sufficient area to provide a path for the heat into the surrounding ambient air. This is the purpose of the HM199 heatsink. Metals are good conductors of heat, and can provide effective cooling with the heat flowing from a warmer area to a part of the heatsink which is cooler.

Ultimately the heat is either carried away by the surrounding ambient air, or by radiation. At the temperatures at which the HM199 operates radiation plays a very small part in effectively cooling the surfaces.

In cooling the heatsink, the air in contact with the heatsink is warmed, and a convection flow over the surface is induced, the warmer air

being less dense and rising, to be replaced by cooler air. In this way the heat is carried away.

If measurement shows this to still be inadequate, and it is not possible to increase the surface area of the heatsink, then it may be necessary to provide a flow of forced air to make the cooling more efficient.

While measurement of surface temperatures in a sample may indicate a small thermal margin on a new appliance, it must be remembered that a poorly situated heatsink where dust and fluff can accumulate will lose efficiency as this unwelcome insulating layer builds up. Some margin, and filter cleaning procedure must be allowed to take this into account.

13.3.2 TRIAC SPECIFICATIONS

The triac BTA208X-600E maximum junction temperature is 125 °C and its thermal resistance to the mounting surface on the heatsink (with white heat conducting heatsink compound) is 4 K/W. At 6 Amps load current, its power dissipation is 7.5 watts giving a temperature rise from the heatsink mounting point to the junction of 30 °C.

Therefore the temperature of the heatsink at the mounting point should not exceed $(125 - 30) = 95$ °C

Thus allowing for measuring errors, and a margin for degradation of the thermal path to the ambient in time, it would be advisable to not allow the heatsink to exceed 85 °C at the mounting point after extended operation. Also, at temperatures much higher than this it would be seen as a risk of skin burns if the hot metal was touched.

13.3.3 HEATSINK TEMPERATURE RISE

Measurements on the HM199 module gave the following results. In this case

Refrigeration control with audible condensor alarm and lockout

HM199

the temperature was measured on the triac tab by soldering the thermocouple to the tab, and using a fully insulated thermal data logger (Rustrac) floating at mains voltages.

This should give a reading intermediate between the junction and the mounting base. Of the 30°C rise at 6 Amps, assume half is from junction to tab, and half from the tab to heatsink mounting point (15°C).

Subtracting this from the 125 °C maximum junction temperature gives a tab temperature of 110 °C allowed maximum. At 6 Amps load with the HM199 mounted vertically on the laboratory bench the tab temperature rise above ambient was 45 °C. Mounted horizontally, and therefore with less convection cooling available the temperature increased above ambient to 55 °C.

Therefore for a vertically mounted heatsink, with no air flow constraints the maximum ambient would be $(110 - 45) = 65^{\circ}\text{C}$ and for the heatsink horizontally mounted (again on an open laboratory bench), the maximum ambient temperature would be 55 °C.

These results would be improved if the HM199 heatsink was to be well attached thermally to a large area metal surface which is below the ambient air temperature. However if they were to be mounted in an enclosed space with poor air flow, then the maximum permitted ambient would need to be reduced.

13.3.4 CURRENT RATING

The HM199 printed circuit board layout has been designed to carry a run current of 6 Amps at normal operating temperatures. This has assumed a reasonable flow of air over the surfaces of the heatsink and control board assembly. This flow of air will ensure that the local heating of the ambient by the heatsink does not

result in the board surface becoming too hot.

This can be tested by observation of the printed board surface to ensure that the copper conductor tracks and the printed board material are not discoloured through heat.

13.4 Radio Frequency Interference

The OM1894 has been designed to be especially insensitive to interference. Even when the thermistors are mounted remotely from the HM199 control module, these signals are well filtered to maintain accuracy and perform as intended. This is important in view of recent changes to the laws with respect to Electromagnetic Compatibility (EMC compliance).

In addition to appliances needing to be insensitive to external sources of interference, these standards also require appropriate measures to be taken to ensure no appliances generate radio frequency interference (rfi) beyond prescribed limits.

For an inductive load such as a compressor motor, there may be a need for filtering using capacitors. However the size, and the best place to connect such a capacitor depends on the load (the construction of the motor, and its characteristics) and the manner in which the internal wiring is routed within the appliance. The characteristics of the motor load may also require that a snubbing circuit is used across the triac. The snubbing circuit also assists towards meeting the rfi limits.

The HM199 has used as initial values for radio frequency interference suppression a Y or X rated 100 nF 250 Vac capacitor from Active to Neutral across the supply terminals. However no snubber network is used, since the OM1894 control IC uses true load current zero-crossing. which

generates very low (if any) interference. Used in combination with a “snubberless” triac, it provides an excellent “EMC friendly” solution.

The HM199 will not exhibit the switching transients of “relay” or electromechanical type thermostats, RFI compared with standard electronic (triac control) type thermostats.

Refrigeration control with audible condensor alarm and lockout

HM199

14 DEFINITIONS3

Data sheet status	
Engineering sample information	This contains draft information describing an engineering sample provided to demonstrate possible function and feasibility. Engineering samples have no guarantee that they will perform as described in all details.
Objective specification	This data sheet contains target or goal specifications for product development. Engineering samples have no guarantee that they will function as described in all details.
Preliminary specification	This data sheet contains preliminary data; supplementary data may be published later. Products to this data may not yet have been fully tested, and their performance fully documented.
Product specification	This data sheet contains final product specifications.
Limiting values	
Limiting values given are in accordance with the Absolute Maximum Rating System (IEC 134). Stress above one or more of the limiting values may cause permanent damage to the device. These are stress ratings only and operation of the device at these or at any other conditions above those given in the Characteristics sections of the specification is not implied. Exposure to limiting values for extended periods may affect device reliability.	
Application information	
Where application information is given, it is advisory and does not form part of the specification.	

15 IES INFORMATION

INTEGRATED ELECTRONIC SOLUTIONS PTY. LTD.
ABN 17 080 879 616

Postal address:

Integrated Electronic Solutions
PO Box 2226
Port Adelaide SA 5015
AUSTRALIA

Street Address:

Integrated Electronic Solutions
1 Butler Drive
Hendon SA 5014
AUSTRALIA

Telephone: +61 8 8348 5200
Facsimile: +61 8 8243 1048

World Wide Web: www.ies-sa.com

Email: IES@ies.sa.com.au

Refrigeration control with audible condensor alarm and lockout

HM199

16 DISCLAIMER

Integrated Electronic Solutions Pty. Ltd. (IES) reserves the right to make changes to both its products and product data without notice.

IES makes no warranty, representation or guarantee regarding the suitability of its products for any particular purpose, nor does IES assume any liability arising out of the use or application of any IES product. IES specifically disclaims any and all liability, including without limitation incidental or consequential damages.

Typical performance figures, where quoted may depend on the application and therefore must be validated by the customer in each particular application. It is the responsibility of customers to ensure that any designs using IES products comply with good practice, applicable standards and approvals. IES accepts no responsibility for incorrect or non-compliant use of its products, failure to meet appropriate standards and approvals in the application of IES products, or for the correct engineering choice of other connected components, layout and operation of IES products.

Any customer purchasing or using IES product(s) for an unintended or unauthorised application shall indemnify and hold IES and its officers, employees, related companies, affiliates and distributors harmless against all claims, costs, damages, expenses, and reasonable legal fees arising out of, directly or indirectly, any claim of loss, personal injury or death associated with such unintended or unauthorised use, even if such claim alleges that IES was negligent regarding the design or manufacture of the relevant product(s).

Life Support Applications:

Products of Integrated Electronic Solutions Pty. Ltd. (IES) are not designed for use in life support appliances, devices or systems, where malfunction can result in personal injury. Customers using or selling IES products for use in such applications do so at their own risk and agree to fully indemnify IES for any damages resulting from such improper use or sale.