

Engineering Sample Information
MODULE ASSEMBLY
REVISION 3.0
2008 Jul 02

HM169

Precision electronic thermostat control for heating and cooling

HENDON SEMICONDUCTORS
1 BUTLER DRIVE
HENDON SA 5014
AUSTRALIA



CONTENTS

| | | | |
|-------|--|-------|---|
| 1 | FEATURES | 14.8 | HM169-08 deep fryer thermostat |
| 2 | GENERAL DESCRIPTION | 14.9 | HM169-09 oven controller thermostat |
| 3 | QUICK REFERENCE DATA | 14.10 | HM169-10 cycling fan speed control (simmerstat) |
| 4 | CONNECTIONS AND LAYOUT | 14.11 | HM169-11 simmerstat heater control (230 V) |
| 5 | CIRCUIT DIAGRAM | 14.12 | HM169-12 simmerstat heater control (110 V) |
| 6 | FUNCTIONAL OVERVIEW | 15 | REFERENCES |
| 6.1 | Technical background | 16 | DOCUMENT HISTORY |
| 7 | IMPORTANT ELECTRICAL SAFETY WARNING | 17 | DEFINITIONS |
| 8 | RATINGS | 18 | COMPANY INFORMATION |
| 9 | CHARACTERISTICS | 19 | DISCLAIMER |
| 10 | COMPONENT FUNCTIONS | | |
| 11 | CIRCUIT DESCRIPTION | | |
| 11.1 | Mains supply voltage | | |
| 11.2 | Mains rated resistors | | |
| 11.3 | Power supplies for low current loads | | |
| 11.4 | Heating / cooling | | |
| 11.5 | Resistive / inductive | | |
| 11.6 | Temperature control range | | |
| 11.7 | Temperature control shaft rotation | | |
| 11.8 | Hysteresis | | |
| 11.9 | Cycling control (Simmerstat) | | |
| 11.10 | Choice of thermistor | | |
| 11.11 | Thermistor mounting considerations | | |
| 11.12 | Thermistor/potentiometer failure table | | |
| 11.13 | Accuracy | | |
| 12 | IMPORTANT APPLICATION CONSIDERATIONS | | |
| 12.1 | Application check list | | |
| 12.2 | Triac junction temperature and limitations with load current | | |
| 12.3 | Triac choice, and triac mounting | | |
| 12.4 | Radio frequency interference (rfi), and EMC compatibility | | |
| 12.5 | OM1682A application information | | |
| 13 | HM169-00 GENERIC UNCOMMITTED MODULE | | |
| 14 | HM169 STANDARD CIRCUIT MODULES | | |
| 14.1 | HM169-01 freezer thermostat | | |
| 14.2 | HM169-02 refrigerator thermostat | | |
| 14.3 | HM169-03 refrigerated water cooler thermostat | | |
| 14.4 | HM169-04 water bed thermostat | | |
| 14.5 | HM169-05 room heater thermostat | | |
| 14.6 | HM169-06 hot water service thermostat | | |
| 14.7 | HM169-07 boiling water thermostat | | |

1 FEATURES

- Precise Temperature Control
- Configurable for heating or cooling applications
- Zero-Crossing Load Switching
- Trip temperatures set by selected resistor values. May be set by the user
- Preset hysteresis
- User adjustable thermostat temperature settings
- Designed to drive inductive loads (compressor or fan motors) or resistive loads
- Used with NTC Thermistor temperature sensors
- Simmerstat function also available

2 GENERAL DESCRIPTION

The HM169 is an electronic thermostat control module which has been designed to allow a variety of control applications to be satisfied by the choice of position and value of components on a printed circuit board assembly. Based on the OM1682A Precision Thermostat Control Integrated Circuit, it can be configured to a wide variety of thermostat configurations and temperatures. It is capable of being configured for heating or cooling applications. For example, the zero crossing switching of a resistive load, or for the control of inductive loads such as refrigerators, freezers, air conditioners or fans.

The HM169 is available in a number of basic variants which are listed and very briefly described in this document, as well as being able to be made to suit specific customer requirements. These basic variants cover a range of applications, each having its own data sheet and circuit.

The use of the OM1682A Precision Temperature control IC provides improved accuracy, and improved reliability over mechanical solutions.

3 QUICK REFERENCE DATA

| SYMBOL | PARAMETER | CONDITIONS | MIN | TYP | MAX | UNIT |
|--------|-------------------------------------|-----------------|-----|-----|-----|------|
| VSUP | AC supply voltage | (note 1) | 216 | 230 | 253 | V |
| ISUP | control supply current | controller only | – | 7 | – | mA |
| ILOAD | load current | (note 2) | – | – | 6 | A |
| Tstg | storage temperature range | | –25 | – | +85 | °C |
| Tamb | operating ambient temperature range | in free air | 0 | – | +45 | °C |

Note

1. The operating voltage range can be set to any desired ac range by selection of power supply resistors. Application circuits are easily designed for 100–120 V, or even an extended voltage range such as 100 to 250 V. See the application note AN001 “Power supply circuits for the OM1682A triac controller IC applications”.
2. The HM169 heatsink will permit load currents of up to 6 Amps if it is mounted with a reasonably free flow of air across the heatsink surface. Load currents up to 10 Amps may be used with additional heat dissipating capability, together with triac temperature measurement in situ to demonstrate that under worst case ambient temperatures the triac junction temperature remains within ratings.

4 CONNECTIONS AND LAYOUT

Dimensions: 104 x 95 mm.

Height (including the heatsink) 36 mm.

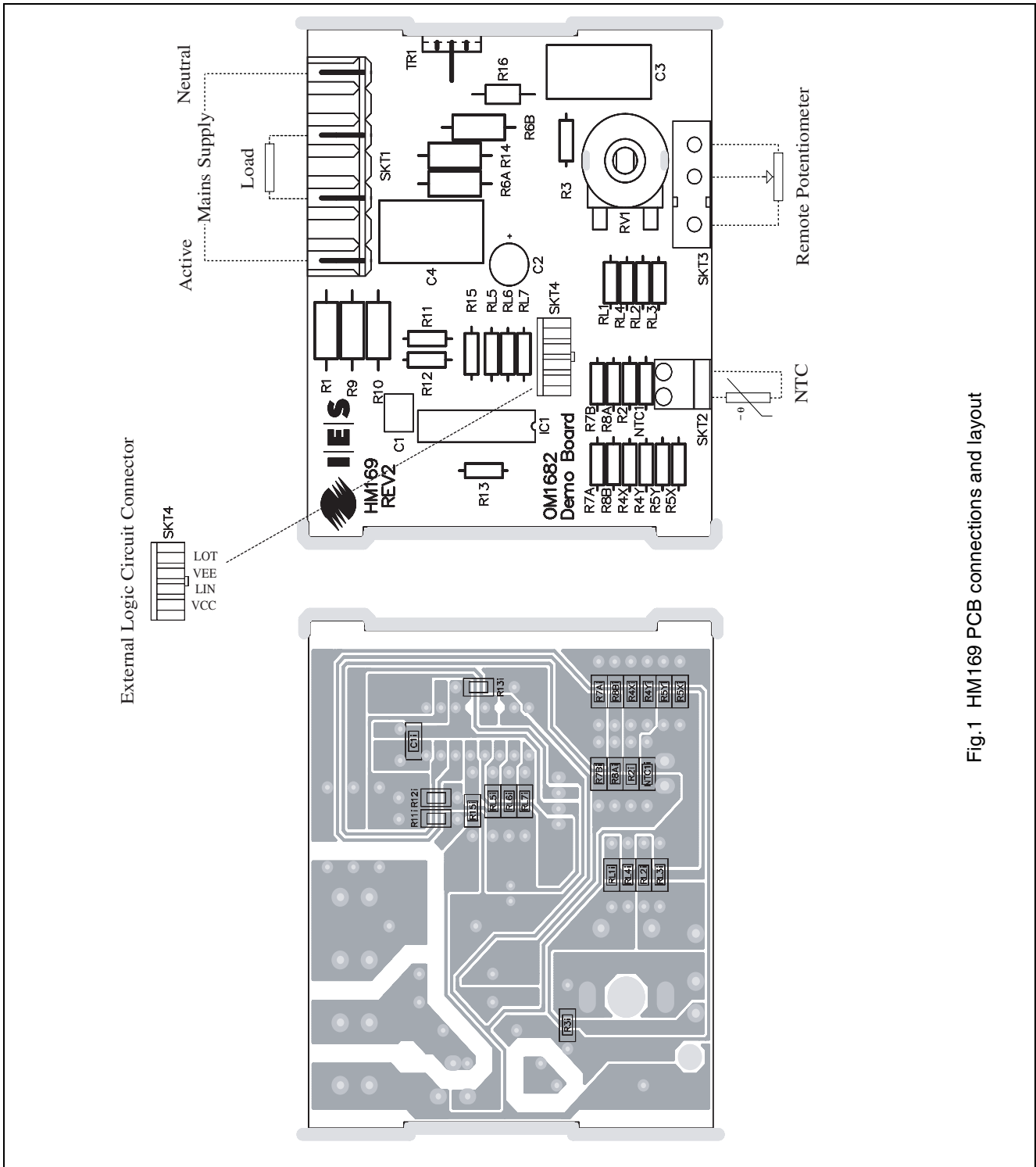

Fig.1 HM169 PCB connections and layout

5 CIRCUIT DIAGRAM

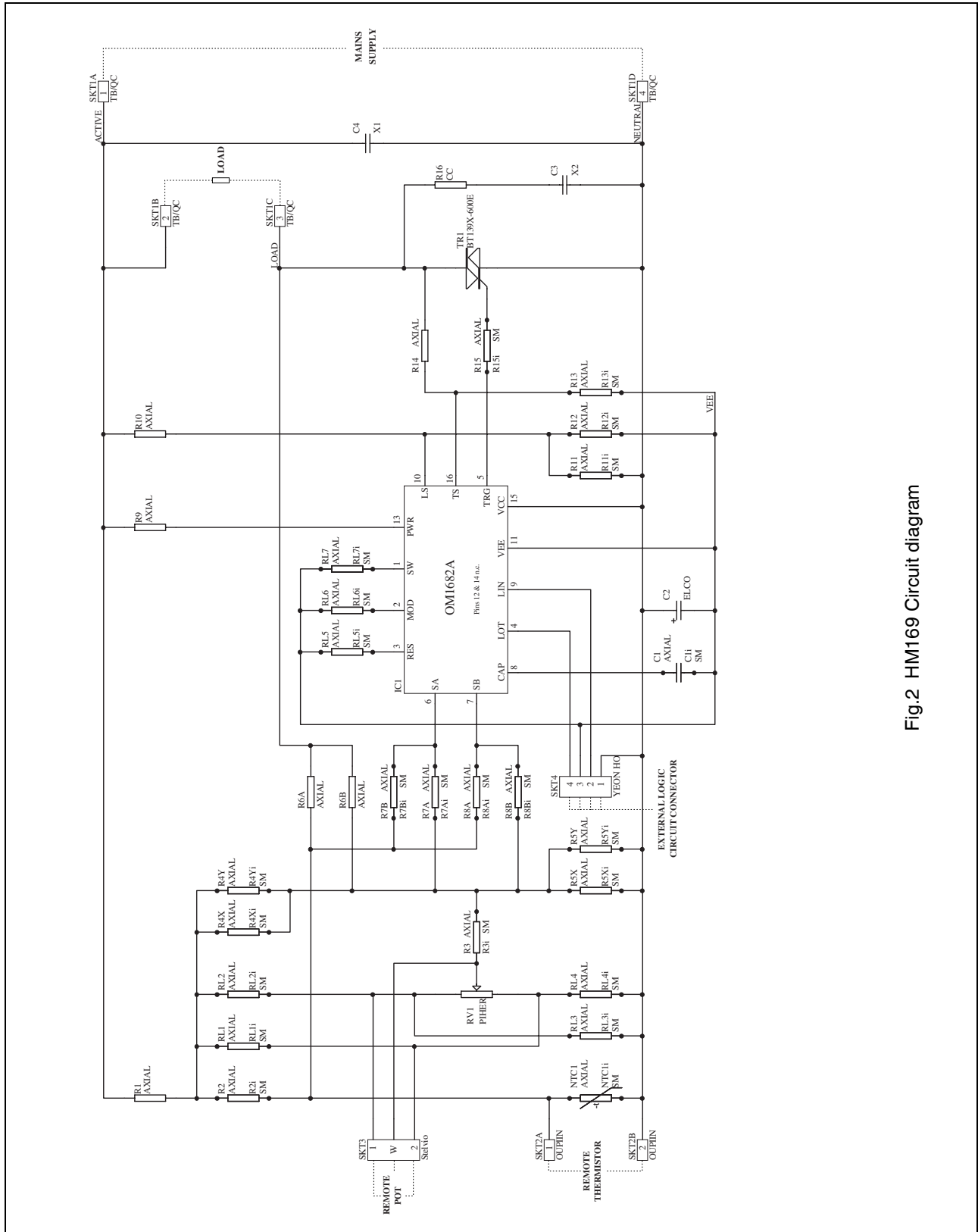

Fig.2 HM169 Circuit diagram

6 FUNCTIONAL OVERVIEW

The HM169 electronic control module provides a general purpose core control module for triac control of a variety of applications. It has provision for a large number of component options to be used allowing a wide range of possible user requirements to be covered through the selection and placement of a few components which are customised for each specific application.

Some versions of the HM169 are briefly described in this specification. Each has its own more detailed specification, including a parts list, and each has a supporting temperature calculation spreadsheet and its power supply calculation software. These and other applications can be addressed by following a documented design process to select suitable component values, and then, by adding these components to the basic HM169-00 uncommitted module the required module can be quite easily manufactured. Less common functions (for example use at another mains voltage) can also be easily accommodated by choice of the components used.

The HM169-00 version consists of the basic HM169 printed circuit board already assembled with some of the surface mount and other key common parts, providing a basic module which can be more easily customized to whichever circuit a designer might wish to assemble, than by starting with the unpopulated bare board.

The versions of the HM169 designated by different suffix numbers which have been mentioned in this specification provide examples of successful designs for typical applications, as well as providing examples the design process. The data sheets for each of these variants describe in more detail which added

or changed components are needed with the standard HM169-00 circuit, and highlight important application information specific to these applications.

In a normal application the core HM169-00 unit (without the customizing resistors) is made up into a finished product by adding readily available axial lead resistors. This has been chosen as the preferred custom assembly method, rather than having a design based on surface mount components which can be difficult for an inexperienced person to use.

6.1 Technical background

The HM169 contains a zero-crossing triac driver OM1682A (IC1) for electronically controlling a load, and in its most common applications thermostatically controls the load by using an external NTC (Negative Temperature Coefficient) thermistor as the temperature sensor. The load function may be either heating or cooling (e.g. a hot water heating element, room heater, fan or a refrigeration compressor motor) and this load may be resistive or inductive in nature. The necessary changes to suit each load, and to set the switching temperatures or conditions required, are made by selection and placement of additional components (mainly axial leaded resistors) on the basic HM169-00 control module.

The HM169-00 module is already assembled with an OM1682A IC, the timing & supply capacitors and a setting potentiometer. Before a functioning module can be completed several questions need to be answered, resistor values calculated, then these components together with the chosen triac are soldered in place to complete the module.

For a detailed description of the functioning of the OM1682A integrated circuit refer to the Data

Sheet "OM1682A Precision Triac Control Thermostat". There are also application notes which describe in detail the design considerations for the power supply and also for the input bridge configurations of circuits using the OM1682A.

These are: AN001 'Power supply circuits for OM1682A triac controller IC applications'.

AN003: 'Input sensing bridge design for the OM1682A triac controller IC'.

To assist in the calculation of the input bridge resistors, and to provide a graphical picture of the temperature control curve, the example control circuits are each provided with an Excel spreadsheet (HM169-xx.xls) in which available practical resistor values can be 'tried' and the resulting changes in temperature trip points observed.

Also the OM1682.exe software program is available on two floppy disks for installation on an IBM compatible PC to make calculation of the power supply components a simple and straight forward task.

The component numbering in these data sheets and the Excel temperature calculation spreadsheet use the same numbers for the components; however the resistor numbers used in the OM1682.exe program and its printed output differ as follows:

R8 in this data sheet = R5 in OM1682.exe (Power to PWR)

R9 in this data sheet = R2 in OM1682.exe (Power to LS).

R10 in this data sheet = R3 in OM1682.exe (LS adjust to negative).

R13 in this data sheet = R1 in OM1682.exe (gate series resistor).

R16 in this data sheet = R4 in OM1682.exe (LS adjust to positive).

Note that in some applications not all of these resistor positions are occupied.

7 IMPORTANT ELECTRICAL SAFETY WARNING

The HM169 circuit is connected to the mains electrical supply and operates at voltages which need to be protected by proper enclosure and protective covering. While it has been designed to conform to relevant Australian and overseas Standards (such as AS3300 and AS3313), it should only be used in a manner that ensures the appliance in which they are used complies with all relevant safety and other requirements.

The board must be mounted with non-conductive clips, and positioned such that the minimum creepage distances from the circuit assembly to earth, and between high voltage points is not transgressed.

The NTC element is electrically live and connected to the mains, and must therefore be electrically insulated. Also creepage distances must be maintained for all live parts in the circuit and its wiring, especially with respect to the NTC thermistor.

It should be noted that there are Mains Voltages on the circuit board. Adequate labelling should be attached to warn service personnel, and others, that this danger exists.

The control board assembly must be mounted, preferably with the heatsink vertical, with sufficient free air flow across its surface to prevent the heat dissipated in a number of critical components from causing an unacceptable rise in the ambient temperature.

The board should be mounted in a place that is clean and dry at all times, not subject to condensation or the accumulation of dust and other contaminants.

8 RATINGS

Limiting values in accordance with the Absolute Maximum System (IEC 134).

| SYMBOL | PARAMETER | CONDITIONS | MIN | TYP | MAX | UNIT |
|----------|-------------------------------------|---------------------|-----|-----|-----|------|
| VSUP | AC supply voltage | (note 1) | 216 | 230 | 253 | V |
| ISUP | control supply current | controller only | – | 7 | – | mA |
| ILOAD | load current | (note 2) | – | – | 6 | A |
| ISTARTUP | startup surge load current | (5 seconds maximum) | – | – | 16 | A |
| Tstg | storage temperature range | | –25 | – | +85 | °C |
| Tamb | operating ambient temperature range | in free air | 0 | – | +45 | °C |

Note

- The operating voltage range can be set to any desired ac range by selection of power supply resistors. Application circuits are easily designed for 100–120 V, or even an extended voltage range such as 100 to 250 V. See the application note AN001 “Power supply circuits for the OM1682A triac controller IC applications”.
- The HM169 heatsink will permit load currents of up to 6 Amps if it is mounted with a reasonably free flow of air across the heatsink surface. Load currents up to 10 Amps may be used with additional heat dissipating capability, together with temperature measurement in situ to demonstrate that under worst case ambient temperatures the triac junction temperature remains within its published ratings. These current ratings are suited to the triac commonly used in samples, the BT139X-600E, other loads may be better suited to design with another triac which will require different peak current ratings.

9 CHARACTERISTICS

A table of characteristics is given for typical example applications as individual application circuits. These are published as separate data sheets (types OM169-xx). Note that these circuits will also depend on the choice of components external to the HM169 module, such as the thermistor to be used and its suitability for the chosen temperature range.

The choice of resistor values can be easily re-calculated to give another operating temperature (or other characteristic) depending on the

specific needs of a particular application.

The HM169 uses very small currents, and generally has a total power dissipation of less than 1.5 watts. However the heat dissipated in the triac is significant, and its heatsink temperature, and how effectively it is cooling the triac, must be checked.

After explaining each component function, application specific considerations are addressed in the following section. Some suggestions are also given for typical values of resistors.

10 COMPONENT FUNCTIONS

Table 1 lists the components of the HM169 with a brief description of their function. By also referring to the circuit of the HM169 it can be seen that resistors are used in different positions to establish the different required functions. As so many options need to be covered for all of the different applications, only a subset of the possible resistors are needed in any single specific application.

Table 1 HM169 component list and function

| COMPONENT | DESCRIPTION |
|-----------|---|
| R1 | Resistor for top arm of sensing side of the bridge (NTC side). Mains rated |
| R2 | Resistor for top arm of setting side of the bridge (potentiometer side). Mains rated |
| R3A | Feedback from LOAD. For hysteresis with cooling load. Mains rated |
| R3B | Feedback from LOAD. For hysteresis with heating load. Mains rated |
| R4A | Current drive resistor from setting bridge junction to SA. Heating input sense |
| R4B | Current drive resistor from sensing bridge junction to SA. Cooling input sense |
| R5A | Current drive resistor from sensing bridge junction to SB. Heating input sense |
| R5B | Current drive resistor from setting bridge junction to SB. Cooling input sense |
| R6 | Resistor parallel to potentiometer (adjust range or fixed single setting) |
| R7 | Resistor in series with potentiometer. To set potentiometer adjustment span |
| R8 | Power supply boost resistor. If addition DC power supply is needed. Mains rated |
| R9 | Mains synchronizing and power supply resistor. Mains Rated |
| R10 | Resistor to adjust triac gate drive timing (also for start timing with inductive load). Usually 220 k |
| R11 | Triac T2 feedback resistor for inductive loads. Mains Rated |
| R12 | Resistor to adjust triac gate drive run timing with inductive loads. Usually 220 k |
| R13 | Gate drive setting resistor for the triac |
| R14 | Snubbing resistor for inductive loads. Must be carbon composition |
| R15 | Resistor to replace sensor (NTC thermistor) for simmerstat application |
| R16 | Timing resistor fine adjustment for zero crossing |
| | |
| RL1 | Link fitted for an inductive load |
| RL2A | Link to determine sense of rotation of potentiometer adjustment |
| RL2B | Link to determine sense of rotation of potentiometer adjustment |
| RL3 | Link to determine control mode with respect to mains cycle polarity |

| COMPONENT | DESCRIPTION |
|------------------|---|
| RV1 | Potentiometer, to set the control point within the design range |
| Shaft | Plastic clip-in shaft for potentiometer adjustment |
| NTC1 | NTC Thermistor or other electronic sensing device |
| C1 | Timing capacitor for input bridge sensing. Filter and smoothing of output switching |
| C2 | Power supply filter capacitor. Electrolytic |
| C3 | Mains rated interference suppression. For rfi with inductive load |
| C4 | Snubbing capacitor. For inductive load. For dv/dt rating of the triac, and rfi |
| IC1 | OM1682A Precision thermostat IC |
| TR1 | Triac. Usually BT139X-600E |
| PCB | Printed circuit board |
| Plug | Two pin PCB mounting connector for NTC lead to plug in. RS 453-151 |
| Connecting strip | 4 Pin connecting strip for mains and load connection. Chiri 4 pos 10 mm CUF10/4 |
| Screw strip | 4 position plug-in for screw termination of mains and load leads. Chiri |
| Triac clip | Triac spring mounting clip |
| Thermal grease | White thermal heat conducting grease for use between triac and heatsink |
| Nylon mount (2) | Nylon mounting clips for PCB to heatsink |
| Heatsink | Aluminium folded heatsink |

A basic core set of components are included in the HM169-00. This enables a user to choose values for a custom application. It includes a BT139X-600E triac (although this is not very suitable for designs controlling powers below 600 W)

The HM169-00 also includes the rfi suppression components which are generally needed for inductive loads. This enables an HM169-00 to quickly be made up to satisfy any specific need without worrying about finding these less easily obtained parts. However, for larger quantities, these can usually be omitted for resistive load applications, and it may be possible to use smaller capacitor

values for some inductive load applications.

Application examples are described briefly in this data sheet, with each model having its own supplementary data sheet giving full details of which additional components are needed, as well as in one or two cases where existing parts in the OM169-00 need to be replaced or supplemented.

11 CIRCUIT DESCRIPTION

This section describes the circuit design approach used in application of the OM1682A precision control IC. In the HM169 there are many options to satisfy different application needs,

temperature ranges, and loads currents.

11.1 Mains supply voltage

The HM169 circuits using the OM1682A have been designed in Australia, where the normal supply voltage is 230 Volts. However the OM1682A is interfaced to the mains supply by a number of high voltage resistors which can be selected to suit the design supply voltage range.

The considerations involved in choosing the power supply and triac drive components is discussed in detail in the application note AN001, 'Power supply circuits for OM1682A triac controller IC applications'. Also the OM1682.exe power supply design

program greatly helps in power supply design, covering worst case calculations for both high and low voltage limiting conditions.

At the lowest value of the supply voltage there must be sufficient supply current to power the OM1682A, and to provide the gate current drive for the triac. When the supply is at its highest, then the power dissipation of the power supply resistor(s) must not be excessive.

11.2 Mains rated resistors

The power supply resistors, and those resistors in the temperature sensing bridge which carry most of the mains supply voltage should be chosen to give guaranteed performance with high ac voltages. Mains rated resistors, such as the Vishay VR37 or VR25 series are strongly recommended. Although standard metal film resistors may be able to withstand the nominal supply voltage they can become unreliable when subject to the normal mains transients which are known to occur.

11.3 Power supplies for low current loads

One of the inherent design features of the OM1682A is that its current consumption is much smaller than other similar mains control devices. Plenty of energy is available at 240 Volts, but for the electronic control voltages below 10 Volts as used in an integrated circuit, the current supply is very limited. The current consumption of the OM1682A is less than 0.5 mA including the current requirements for the input bridge circuit. However the triac gate needs a current drive of 20 mA (e.g. for the sensitive gate BT139X-600E) or more to ensure that sufficient current is flowing for an initial cold start (worst case); this current must be applied to the gate until the current

flowing through the load has reached its holding current.

A smaller load current means that the gate pulse must be applied for a longer time until the holding current is reached. Thus a wider gate pulse will need a higher average current from the power supply.

Therefore for the design of circuits to control smaller loads (low power and lower typical load currents) involves a larger average power supply current and therefore increased dissipation in the power supply resistors. The OM1682.exe power supply design program is very useful in finding the best combination of resistor values to ensure reliable worst case performance.

11.4 Heating / cooling

If the application is for the control of a heater, R4 and R5 are used in the "A" positions. For a cooling application they are in the "B" position. In most applications they are equal and their value (in combination with C1) determines the time constant of the ON / OFF cycling when the temperature is close to the control setting. Values of 220 k 1% are usually suitable. The voltage across these resistors (R4 and R5) is small so 0.4W standard film resistors are adequate.

11.5 Resistive / inductive

For a resistive load (i.e. a fan heater or water heater) the low ohm link resistor (L1) to pin 3 of the IC is not required.

For an inductive load (i.e. a refrigerator compressor) the resistive link L1 is needed, as well as R11 220 k 5%. this resistor must be mains rated and 0.5 W, i.e. Vishay VR37. An inductive load may require the addition of mains radio frequency interference (rfi) filtering with

capacitors (and/or inductors), possibly with a snubbing network across the triac.

11.6 Temperature control range

One approach to the design of an application circuit is to use an NTC thermistor such that the difference between its resistance at the required upper temperature limit and at the lower required temperature limit is similar to (a little less than) the value of RV1 (i.e. 4.7 k Ω). R6 is chosen such that R6 in parallel with RV1 equals this value. R7 is then chosen to be equal to the NTC resistance at the required upper temperature limit. Example, a hot water urn to control from 90 °C to 104 °C. The Vishay 100 k Ω thermistor (code number 2322-640-63104) has a nominal resistance of 8,042 Ω at 90 °C and 5,151 Ω at 104 °C, that is a resistance change of 2,891 Ω . An 8.2 k Ω resistor in parallel with the 4.7 k Ω potentiometer equals 3.0 k Ω (which includes an allowance for the tolerance of the potentiometer). Therefore in this example use R6 = 8.2 k Ω and R7 = 5.1 k Ω .

Note: The tolerance on the control range is determined mainly by the tolerances of the Potentiometer and NTC. The use of quality, tight tolerance components will ensure consistent control of the temperature.

11.7 Temperature control shaft rotation

The clip-in potentiometer shaft for adjusting the set temperature or duty cycle can be either inserted through a hole in the heatsink and the printed circuit board, or directly into the potentiometer from the component side. Depending on how the board is mounted and which surface faces forward, the direction of rotation of the potentiometer will vary. However a zero ohm resistor link (RL2) has

provision for two positions on the printed circuit board, and can be chosen to give the desired direction by placing the link in position RL2A or RL2B. The position chosen for this link will offer clockwise or anticlockwise rotation for increasing resistance.

11.8 Hysteresis

The OM1682A IC has an inherent minimum time cycle (set by the choice of the input resistors to the SA and SB pins of the OM1682A, and the filter capacitor on CAP). This is modified by the use of a hysteresis setting resistor, and the effective total hysteresis can be increased or decreased by the addition of R3 in the A or B position, depending on whether the HM169 is being used for heating or for cooling.

In thermostat applications with the temperature feedback from the NTC thermistor, the cycle time is largely determined by the thermal mass being heated or cooled, together with the power being controlled. This means that in a typical application, with judicious application of hysteresis, the minimum cycle time derived from the difference between the SA and SB input currents to the OM1682A being summed in the capacitor connected to the CAP pin makes an insignificant contribution to the overall cycle timing. Adjustment of the hysteresis resistor has a much more significant effect allowing the response time of the system itself to determine how fast it cycles.

In the simmerstat circuit, hysteresis is applied in the opposite sense to that normally used in thermostat applications with temperature feedback, and the CAP pin capacitor charge and discharge rates alone set the cycle time.

Heating: Adding a resistor to position “R3B” increases the hysteresis and

increases the cycling time between ON and OFF; that is the ON and OFF points exhibit a larger difference, or greater hysteresis. Conversely, adding R3 to position “R3A” reduces the hysteresis and therefore forces more frequent cycling. EMC standards may require the use of an increased hysteresis figure to ensure the cycling is not too frequent with a high power load, causing fluctuation of the mains supply voltage.

Cooling. The positions of R3 are reversed for cooling. i.e. R3A is added to increase the hysteresis and R3B reduces it.

Hysteresis resistor values between 220 k Ω and 22 M Ω are common. The selection of this value depends very much on the application and is left to the designer. This resistor must be mains rated and suitably power rated, i.e. Vishay VR25 or VR37 depending on the power dissipation.

11.9 Cycling control (Simmerstat)

The hysteresis setting resistor can be used to generate a cycling controller which does not use a temperature sensor. In this case the potentiometer adjustment can be set up so as to vary the ON time from fully ON with the potentiometer at minimum resistance, to fully OFF at maximum resistance.

Typical applications in this simmerstat mode are for fan control (where the inertia of the fan permits burst mode firing) or for heating with fixed proportional power input. In both cases without any temperature feedback.

In more complex circuits some temperature compensation can also be applied to modify the duty cycle a little depending on the ambient temperature.

11.10 Choice of thermistor

It is necessary to choose a thermistor which has a resistance of at least 2,000 Ω at the operating temperature, otherwise the voltage across the thermistor will be too small to provide accurate and adequate sensitivity. This means that a different thermistors are usually chosen for heating and for cooling applications.

It is also important to ensure that the thermistor can be mounted in a way that is electrically safe, is protected from the access of moisture, and which provides good thermal contact to the intended thermal measuring point.

11.11 Thermistor mounting considerations

As the thermistor is electrically live to mains voltages it must be adequately insulated for use in each application. A range of insulated thermistors are available, and there are a number of important issues which must be considered in mounting them.

The best way in which to mount the thermistor is to clamp along the length of the lead for about 50 mm starting just clear of the sensing “head” of the lead. Ideally the plastic head of the leaded thermistor should all be clear of the mounting clamp by a distance of at least 1 to 5 mm.

The sensing head of an insulated leaded thermistor should never be clamped.

The plastic covered thermistor does not have a large thermal mass, and especially in moving air, will arrive quite quickly at a temperature very close to that of the ambient air. The clamping means can also allow heat to flow to/from the copper wires leading to the thermistor, and can provide a significant modification to the temperature seen by the thermistor. If the sensing point is also

associated with a significant thermal mass such as a shelf or a panel, averaging, and a thermal delay to sense ambient changes can result, possibly providing much more desirable response characteristics. However, mounted in an active air stream, without thermally conductive paths to surrounding objects, it can give sensing which is very sensitive to even small variations in air temperature.

11.12 Thermistor/potentiometer failure table

As the thermistor is remote from the HM169, there is a possibility that these wires may either short, or may become open circuit. Table 2 below shows the result with such a failure. It also shows what occurs if the wiper on the potentiometer becomes open circuit through contamination from dust etc.

Table 2 Sensor potentiometer failure table

| MODE | COOLING | HEATING |
|-----------------|---------------------------|---------------------------|
| NTC open | No cooling | Continuous heating |
| NTC short | Continuous cooling | No heating |
| Pot wiper open | Cool to coolest set point | Heat to lowest set point |
| Pot wiper short | Cool to warmest set point | Heat to highest set point |

11.13 Accuracy

Using thermistors chosen from the Vishay range, the typical best thermistor accuracy is 5 % (a little over 1 °C error/spread) although more accurate thermistors are available (3%, 2%). With the choice of 1% resistors in the measuring section of the circuit (R1 to R7), the total temperature error will be less than

2 °C. In a production batch most units will be much closer to the nominal value (say 80% or more within 1 °C).

When a potentiometer is used to adjust to the required temperature an error is introduced from the tolerance of the potentiometer (usually 10 to 20%), and the designer will allow for this by making the adjustment range wider than that specified). However, it obviously becomes possible to set the temperature to any desired point within its range. The input measuring circuit is a balanced bridge, and therefore any variation in mains voltage is cancelled, and has no effect on the set temperature. Likewise the input measuring circuit of the OM1682A is also balanced.

12 IMPORTANT APPLICATION CONSIDERATIONS

The points below must be considered before a final HM169 design is acceptable for performance and reliability in a given required function.

12.1 Application check list

1. What is the application? Heating or Cooling?
For heating the load is powered when the temperature is below the set point.
For cooling, with a refrigerator compressor, or by a fan, it requires load power when the required temperature is higher than the set temperature.
2. Is the load resistive or inductive?
A resistive load is more easily controlled. The OM1682A thermostat IC has provision to control an inductive load such as a compressor or a fan motor.
3. What temperature control range is required? The HM169 can be configured to operate at a fixed temperature, the potentiometer

on the HM169 module can be used to adjust it to the required temperature (within the module design range), or it can be used without a temperature sensor in simmerstat mode, with a manually set average power output through a variable duty cycle.

4. What hysteresis switching points are needed? For example, in a heater, the hysteresis is the difference between the temperature at which it calls for heat, and the heater is turned ON, and the temperature at which it switches OFF once that temperature is achieved. A larger hysteresis figure results in a longer cycle time, and a larger variation in temperature between the ON and OFF points in normal operation. In the HM169 the hysteresis can be set to best suit a specific application.
5. What will be the current load under normal conditions? The load current must be capable of being controlled by the triac. This must be considered both for normal operation as well as for any possible abnormal conditions. For example, a refrigerator compressor motor presents an increased current load under stall and starting conditions. Similarly, incandescent lamp loads can present appreciable inrush currents when turned on with a cold filament.
6. Are the triac current loads acceptable for the HM169 module?
For loads of less than 10 Amps the copper tracks on the HM169 printed circuit board are adequate to carry this current.
7. What power will be dissipated in the triac? The triac has a rated

maximum operating junction temperature of 125 °C, and if this temperature is exceeded it is possible that the triac will switch ON (and may stay ON) even without a gate signal. It is therefore necessary to ensure that under all operating conditions, including possible abnormal conditions, the junction will not exceed this maximum temperature. This is done by using a heatsink to conduct the heat away from the triac, and to dissipate this heat via the free flow of air across a sufficiently large heatsink surface area.

12.2 Triac junction temperature and limitations with load current

The HM169 control circuit is an electronic controller using small currents. However the load currents can be quite large, and adequately rated wiring must be used for this high current part of the circuit.

For load currents over 6 amps problems can arise for two reasons. The copper tracks on the printed circuit board are unable to carry such high currents without their self-heating becoming a problem if the ambient temperature is high. Secondly, also a problem of high ambient, the triac junction may not be maintained at all times below 125 °C.

This means that if the ambient is likely to be warm, and air circulation around the HM169 is inhibited, measurements of triac temperatures while it is running will need to be carried out to ensure that there is an adequate margin and that overheating will not occur.

When used to control very high current loads: The HM169 controller may also be used with high current triacs with the triac mounted remote from the HM169 on a large heatsink

with wiring capable of carrying the load current.

The full load current flows from the mains electrical supply through the triac switch and the load. For large currents (and especially for all load currents over 10 Amps with a suitable triac and adequate heatsink) this circuit should be established externally to the connections to the HM169. The gate signal connections should be made from the HM169 triac gate solder pad directly to the triac gate. Also the triac T1 connection which completes the circuit loop for the gate drive should be made between T1 of the triac and the neutral connection on the HM169 module.

The wiring for the gate and the T1 return circuit are small signal circuits only, carrying no more than 50 mA. Also the active supply current to the HM169 is only about 4 mA, and does not need high current capability wiring.

Summary (high load current requirements): For high currents connect directly from the Active to the Load, then from the Load to the triac T2, and returning from triac T1 to Neutral. These are all high current connections, and plugs, sockets, wiring, and soldered connections must have been designed to carry the full load current. The HM169 control module, which only presents a low current load can then be connected with small signal wiring (but still requiring adequate mains rated insulation and physical strength). The Neutral and Gate connection on the HM169 should be connected as close to the terminals T1 and gate on the triac as possible to exclude voltage drop in the main current path from interfering with the gate drive circuit.

12.3 Triac choice, and triac mounting

One recommended range of triacs for use with the HM169 are from the NXP family of BT136 to BT139, or BTA140, (although not limited to this range of devices) depending on the load currents to be controlled. These are available in the non-insulated TO-220 package, or in the moulded "F" and "X" packages where the tab of the package is enclosed in the plastic moulding.

On assembled samples of the HM169 the triac used is the BT139X-600E. The X package is fully enclosed in plastic, and meets electrical standards for insulation and creepage distances when assembled on an earthed heatsink.

See the Mounting Instructions in the Philips Semiconductors Triac Data Book (SC03).

Various attachment methods are available. The spring clip used in the HM169 provides one of the best means of attachment, avoiding the problem of over-tightening of a screw or eyelet attachment. Screw connection with pressure washers is a common means. The use of a rivet is also common, although if the tooling is not set to give precisely the right holding pressure; there is a risk that if it is loose the thermal resistance is too high and the junction overheats; and if it is over compressed it will flex the soft metal tab and fracture the crystal.

With the insulated package the capability to dissipate heat is degraded, but there is not the same problem in needing to insulate the heatsink. Consideration must also be given to surface creepage distances from live to earthed metal parts of the assembly. In particular this includes the triac pins where they enter the moulded package, and on the

opposite end of the package, the points where the metal frame is visible. The “X” package is specially designed to meet creepage requirements at the pins by providing a 0.5 by 2.5 mm groove in the package to give a 5 mm total surface creepage to the heatsink, also it does not have the assembly frame visible at the other surface of the package.

In using a TO-220 packaged triac the metal tab, and the rear surface of the packaged device is connected to the T2 of the triac, and is therefore live to the mains. This gives a problem in that it must be electrically insulated for safety reasons, and yet a good thermal connection must also be made to the heatsink. There are a number of ways this problem can be overcome: for example by using a mica washer or other thin electrically insulating spacer.

A smear of thermal conductive grease should always be used between the packaged triac and the heatsink.

12.4 Radio frequency interference (rfi), and EMC compatibility

The OM1682A has been designed to be especially insensitive to interference. Even when the thermistor is mounted remotely from the HM169 control module, the signal is an attenuated mains voltage, and not a signal which might provide radio frequency interference (rfi). This is important in view of recent changes to the law with respect to Electromagnetic Compatibility (EMC compliance) in Australia.

In addition to appliances needing to be insensitive to external sources of interference, these standards also require appropriate measures to be taken to ensure no appliances generate radio frequency interference (rfi) beyond prescribed limits.

When controlling a resistive load, the HM169 using it with loads up to 10 A the OM1682A has been shown to be fully compliant with the standard without requiring any additional components for rfi suppression and filtering. (Unlike many other triac control circuits). This is inherent because of the system of zero-crossing gate control used in this module.

For an inductive load, there is probably a need for a small amount of filtering using mains rated capacitors. However the size, and the best place to connect such a capacitor depends on the load (the construction of the motor, and its characteristics) and the manner in which the internal wiring is routed within the appliance. The characteristics of the motor load may also require that a snubbing circuit is used across the triac. The snubbing circuit also assists towards meeting the rfi limits.

The HM169 has used as initial values for radio frequency interference suppression an X1 rated 100 nF 250 Vac capacitor from Active to Neutral across the supply terminals, together with a typical snubbing network using an X2 rated capacitor applied across the triac.

The snubbing network is a series connected X2 rated mains capacitor (for example: 47 nF, 250 Vac) in series with a 47 ohm carbon composition or wirewound 0.6 watt resistor connected between T1 and T2 of the triac. The first purpose of a snubbing network is to prevent the dv/dt re-triggering when the triac turns OFF. An oscilloscope is needed to determine the rise-time, and check whether it exceeds the rated value for the triac used. As it also helps reduce rfi a snubber network may be worthwhile anyway. The dv/dt measurement on the oscilloscope will depend on inherent design features of

the compressor winding (for example, amongst other characteristics, the stray capacitance to ground).

It is possible to have rfi generated by a zero crossing fired triac driving a large resistive load (>10 A). A small suppression circuit may be required to meet the EMC standards.

12.5 OM1682A application information

There are a number of application notes which detail specific part of the design process for using the OM1682A Precision Triac Control IC. Particularly relevant to the HM169 are:

AN001 Power Supply Circuits for OM1682A Triac Controller IC Applications.

AN003 Input sensing Bridge Design for OM1682A Triac Controller IC.

Excel spreadsheets for each application. These allow standard resistor values to be typed in, with the spreadsheet immediately calculating the resulting switching temperatures for graphical display. This is most helpful in finding acceptable temperature settings which can be achieved with readily available resistors. A spreadsheet is also available which shows simmerstat frequency and duty cycle against resistor and capacitor values.

If significantly different functions are required, spreadsheets can be written to suit these more complex applications. Contact IES for details.

OM1682.exe A program which calculates suitable power supply component values, and greatly simplifies the task of designing the power supply taking into account the gate pulse constraints for various triacs.

13 HM169-00 GENERIC UNCOMMITTED MODULE

On the uncommitted assembly the surface mount and the common through-the-board components are already assembled.

The components which will adapt the HM169-00 to a specific function and operating temperature are not included.

In addition, the two mains rated capacitors, and the snubbing resistor are also included. These are not needed when it is used to control resistive loads. But for inductive loads if the final product in which the HM169 is to be used is to be submitted for EMC assessment (particularly to verify that radio frequency interference levels are below the limit specified in the standards), these capacitors are most likely to be needed. Generally they are not

needed to demonstrate the control function, and they could have been omitted from the HM169 to save cost: but if they are found to be needed later when being tested for approval compliance, then it is better to be aware of the possible likely need before the final production PCB circuit is laid out. The most cost effective position in which to install them is on the controller PCB.

In Table 3 below the parts list of the HM169-00 is given.

The following Table 4 lists the positions in which addition components might be installed to set up the required function, and temperature control points. In addition indicative component value ranges are given that are typical of many of these applications.

For the positions labelled A or B: resistors are required in either the A

or the B positions (the choice of a resistor used in the A or B positions enables the HM169 to be used either for heating or cooling loads: that is to control resistive or inductive loads).

Most of these components are axial leaded components which can be hand formed and soldered in place using a normal soldering iron and electronic solder.

A 1% tolerance has been given for resistors used to set the temperature. A wider tolerance may be used however, but it will give a reduced accuracy for the set temperatures.

R15 is used in the simmerstat application and it is mounted in place of the two pin NTC thermistor connector for NTC1.

The HM169 modules HM169-51 and higher are designs for specific customers and are not included.

Table 3 Parts list for the HM169-00 uncommitted module

| PART | VALUE | DESCRIPTION | MFR | CODE |
|-----------|----------------------|---|--------|----------------|
| PCB | HM160 | printed circuit board | IES | |
| R14 | 220 R | resistor, carbon composition 0.6 W | | |
| RV1 | 4k7 | potentiometer, linear | Vishay | 2322 505 00306 |
| C1 | 220 nF, 25 V | capacitor, SMD chip 1206 | Vishay | 2222 911 56654 |
| C2 | 100 μ F, 10 V | capacitor, ELCO, radial | Vishay | 2222 037 54101 |
| C3 | 100 ν F, 250 Vac | capacitor, mains rated, suppression, Class X2 | Vishay | 2222 336 10104 |
| C4 | 100 ν F, 250 Vac | capacitor, mains rated, suppression, ClassX1 | Vishay | 2222 336 20104 |
| IC1 | OM1682A | integrated circuit | HS | OM1682AT |
| TR1 | BT139X-600E | triac | NXP | BT139X-600E |
| Heatsink | | aluminium folded heatsink | | |
| Grease | | white thermal grease (smear) | | |
| Clip | | spring mounting clip for the triac | | |
| Mounts | 2 off | nylon mounting clips | | |
| Plug | | 2 pin pcb mounting plug for NTC | | RS 453-151 |
| Plug | | 4 pos 10 mm pitch mains connector | Chiri | CUF 10/4 |
| Socket | | 4 pos screw mount socket for mains/load | Chiri | |
| Pot shaft | | clip-in potentiometer shaft | Vishay | 4322 046 20101 |

Table 4 Possible components not included in HM169-00 uncommitted module, with a typical range of component values

| PART | TYP. VALUE | DESCRIPTION | VISHAY CODE |
|------|----------------|-----------------------------------|----------------|
| R1 | 150 k to 1 M | Resistor, axial, 1%, VR37 or VR25 | 2322 242 8.... |
| R2 | 150 k to 1 M | Resistor, axial, 1%, VR37 or VR25 | 2322 242 8.... |
| R3A | 220 k to 22 M | Resistor, axial, 1%, VR37 or VR25 | 2322 242 8.... |
| R3B | 220 k to 22 M | Resistor, axial, 1%, VR37 or VR25 | 2322 242 8.... |
| R4A | 100 k to 470 k | Resistor, axial, 1%, MRS16T | 2322 157 3.... |
| R4B | 100 k to 470 k | Resistor, axial, 1%, MRS16T | 2322 157 3.... |
| R5A | 100 k to 470 k | Resistor, axial, 1%, MRS16T | 2322 157 3.... |
| R5B | 100 k to 470 k | Resistor, axial, 1%, MRS16T | 2322 157 3.... |
| R6 | 1 k to 100 k | Resistor, axial, 1%, MRS16T | 2322 157 3.... |
| R7 | 1 k to 10 k | Resistor, axial, 1%, MRS16T | 2322 157 3.... |
| R8 | 56 k to 220 k | Resistor, axial, 5%, VR37 | 2322 242 13... |
| R9 | 56 k to 220 k | Resistor, axial, 5%, VR37 | 2322 242 13... |
| R10 | 220 k | Resistor, SMD chip, RC11, 0805 | 2322 730 61... |
| R11 | 220 k | Resistor, axial, 5%, VR37 | 2322 242 13... |
| R12 | 220 k | Resistor, SMD chip, RC11, 0805 | 2322 730 61... |
| R13 | 120 to 680 R | Resistor, SMD chip, RC11, 0805 | 2322 730 61... |
| R15 | 1 k to 100 k | Resistor, axial, 1%, MRS16T | 2322 157 3.... |
| R16 | 22 k to 2 M | Resistor, axial, 1%, MRS16T | 2322 157 3.... |
| RL1 | zero ohm link | Low value SFR16 | 2322 181 90019 |
| RL2A | zero ohm link | Low value SFR16 | 2322 181 90019 |
| RL2B | zero ohm link | Low value SFR16 | 2322 181 90019 |
| RL3 | zero ohm link | Low value SFR16 | 2322 181 90019 |

14 HM169 STANDARD CIRCUIT MODULES

Examples of standard applications using typical chosen regulating temperatures.

Each of these example versions of the HM169 thermostat has its own data sheet which shows the characteristics, parts list, and circuit. Also available are the OM1682.exe templates used to calculate the power supply resistors for these application circuits, together with an Excel spreadsheet showing the result of calculating the trip temperatures from the temperature setting resistor values, and the performance graphs showing trip temperatures against potentiometer setting.

14.1 HM169-01 freezer thermostat

Temperature cut-in range -12 to -26 °C. Hysteresis -2 °C.
230 V 0.6 A minimum load current.
Use with a 2.2 kΩ thermistor (e.g. Vishay insulated lead 2322 640 90121).
HM169-01.r
HM169-01.xls

14.2 HM169-02 refrigerator thermostat

Temperature cut-in range 0 to 10 °C.
Hysteresis -2 °C.
230 V 1 A minimum load current.
Use with a 2.2 kΩ thermistor (e.g. Vishay insulated lead 2322 640 90121).
HM169-02.r
HM169-02.xls

14.3 HM169-03 refrigerated water cooler thermostat

Temperature cut-in range 2 to 15 °C.
Hysteresis -2 °C.
110 V 0.6 A minimum load current.
Use with a 2.2 kΩ thermistor (e.g. Vishay insulated lead 2322 640

90121).
HM169-03.r
HM169-03.xls

14.4 HM169-04 water bed thermostat

Temperature cut-in range 20 to 35 °C.
Hysteresis 1 °C.
230 V 1.5 A minimum load current.
Use with a 10 kΩ thermistor (e.g. Vishay insulated lead 2322 640 90121).
HM169-04.r
HM169-04.xls

14.5 HM169-05 room heater thermostat

Temperature cut-in range 20 to 40 °C.
Hysteresis 1 °C.
230 V 4 A minimum load current.
Use with a 10 kΩ thermistor (e.g. Vishay insulated lead 2322 640 90121).
HM169-05.r
HM169-05.xls

14.6 HM169-06 hot water service thermostat

Temperature cut-in range 50 to 70 °C.
Hysteresis 4 °C.
230 V. 4 A minimum load current.
Use with a 100 kΩ thermistor (e.g. Vishay insulated lead 2322 640 90121).
HM169-06.r
HM169-06.xls

14.7 HM169-07 boiling water thermostat

Temperature cut-in range 90 to 105 °C. Hysteresis 1 °C.
230 V 4 A minimum load current.
Use with a 100 kΩ thermistor (e.g. Vishay insulated lead 2322 640 90121).
HM169-07.r
HM169-07.xls

14.8 HM169-08 deep fryer thermostat

Temperature cut-in range 60 to 200 °C. Hysteresis 5 °C.
230 V 2 A minimum load current.
Use with a 2.2 kΩ thermistor (e.g. Vishay insulated lead 2322 640 90121).
HM169-08.r
HM169-08.xls

14.9 HM169-09 oven controller thermostat

Temperature cut-in range 60 to 300 °C. Hysteresis 10 °C.
230 V. 4 A minimum load current.
Use with a 2.2 kΩ thermistor (e.g. Vishay insulated lead 2322 640 90121).
HM169-09.r
HM169-09.xls

14.10 HM169-10 cycling fan speed control (simmerstat)

Duty cycle adjustment range from 0% to 100% power.
230 V. 0.6 A minimum load current.
Cycle frequency at mid setting 0.2 Hz.
HM169-10.r
HM169-10.xls

14.11 HM169-11 simmerstat heater control (230 V)

Duty cycle adjustment range from 0% to 100% power.
230 V. 2 A minimum load current.
Cycle frequency at mid setting 0.01 Hz.
HM169-11.r
HM169-11.xls

14.12 HM169-12 simmerstat heater control (110 V)

Duty cycle adjustment range from 0% to 100% power.
110 V. 2 A minimum load current.
Cycle frequency at mid setting 0.01 Hz.
HM169-12.r, HM169-12.xls

Notes:

15 REFERENCES

1. OM1682A: Precision Triac Controller Thermostat. - Hendon Semiconductors Data Sheet.
2. AN003 Application note: Input sensing bridge design for OM1682A IC.

16 DOCUMENT HISTORY

| REVISION | DATE | DESCRIPTION |
|----------|-------------|--|
| 1.0 | 06 Mar 2000 | Released version |
| 2.0 | 18 Jan 2007 | Updated all references to OM1682A |
| 3.0 | 2 Jul 2008 | Updated to Hendon Semiconductors Philips references changed to Vishay (passives) and NXP (Semiconductors) |
| | | |

17 DEFINITIONS

| Data sheet status | |
|---|---|
| Engineering sample information | This contains draft information describing an engineering sample provided to demonstrate possible function and feasibility. Engineering samples have no guarantee that they will perform as described in all details. |
| Objective specification | This data sheet contains target or goal specifications for product development. Engineering samples have no guarantee that they will function as described in all details. |
| Preliminary specification | This data sheet contains preliminary data; supplementary data may be published later. Products to this data may not yet have been fully tested, and their performance fully documented. |
| Product specification | This data sheet contains final product specifications. |
| Limiting values | |
| Limiting values given are in accordance with the Absolute Maximum Rating System (IEC 134). Stress above one or more of the limiting values may cause permanent damage to the device. These are stress ratings only and operation of the device at these or at any other conditions above those given in the Characteristics sections of the specification is not implied. Exposure to limiting values for extended periods may affect device reliability. | |
| Application information | |
| Where application information is given, it is advisory and does not form part of the specification. | |

Originally published as Philips Report No: PAX/AN93001 Date: May 1993

Authors: Malcolm Kay, Mark Potter, Kym Schwarz.

18 COMPANY INFORMATION

HENDON SEMICONDUCTORS PTY. LTD.

ABN 17 080 879 616

Postal address:

Hendon Semiconductors
PO Box 2226
Port Adelaide SA 5015
AUSTRALIA

Street Address:

Hendon Semiconductors
1 Butler Drive
Hendon SA 5014
AUSTRALIA

Telephone: +61 8 8348 5200

Facsimile: +61 8 8243 1048

World Wide Web: www.hendonsemiconductors.com
www.bus-buffer.com

Email: hendon.info@ies-sa.com.au

19 DISCLAIMER

Hendon Semiconductors Pty. Ltd. ABN 17 080 879 616 (“Hendon”) reserves the right to make changes to both its products and product data without notice.

Hendon makes no warranty, representation or guarantee regarding the suitability of its products for any particular purpose, nor does Hendon assume any liability arising out of the use or application of any Hendon product. Hendon specifically disclaims any and all liability, including without limitation incidental or consequential damages. It is the responsibility of the customer to ensure that in all respects the application in which Hendon goods are used is suited to the purpose of the end user.

Typical performance figures, where quoted may depend on the application and therefore must be validated by the customer in each particular application. It is the responsibility of customers to ensure that any designs using Hendon products comply with good practice, applicable standards and approvals. Hendon accepts no responsibility for incorrect or non-compliant use of its products, failure to meet appropriate standards and approvals in the application of Hendon products, or for the correct engineering choice of other connected components, layout and operation of Hendon products.

Any customer purchasing or using Hendon product(s) for an unintended or unauthorised application shall indemnify and hold Hendon and its officers, employees, related companies, affiliates and distributors harmless against all claims, costs, damages, expenses, and reasonable legal fees arising out of, directly or indirectly, any claim of loss, personal injury or death associated with such unintended or unauthorised use, even if such claim alleges that Hendon was negligent regarding the design or manufacture of the relevant product(s).

Life Support Applications

Products of Hendon Semiconductors (Hendon) are not designed for use in life support appliances, devices or systems, where malfunction can result in personal injury. Customers using or selling Hendon products for use in such applications do so at their own risk and agree to fully indemnify Hendon for any damages resulting from such improper use or sale.